

PROJECT PROPOSAL:

HAND PRINTER

A desktop printing device that produces a tangible replica of a hand written note or a translation of a digital text document. The Hand Printer seeks to attach meaning to a digitally delivered message by striving to mimic the gesture and craft of the human producer.

WHY:

1. Making digital social media tangible.
2. Present alternate forms of comm.
3. Striving to attach meaning to digital.

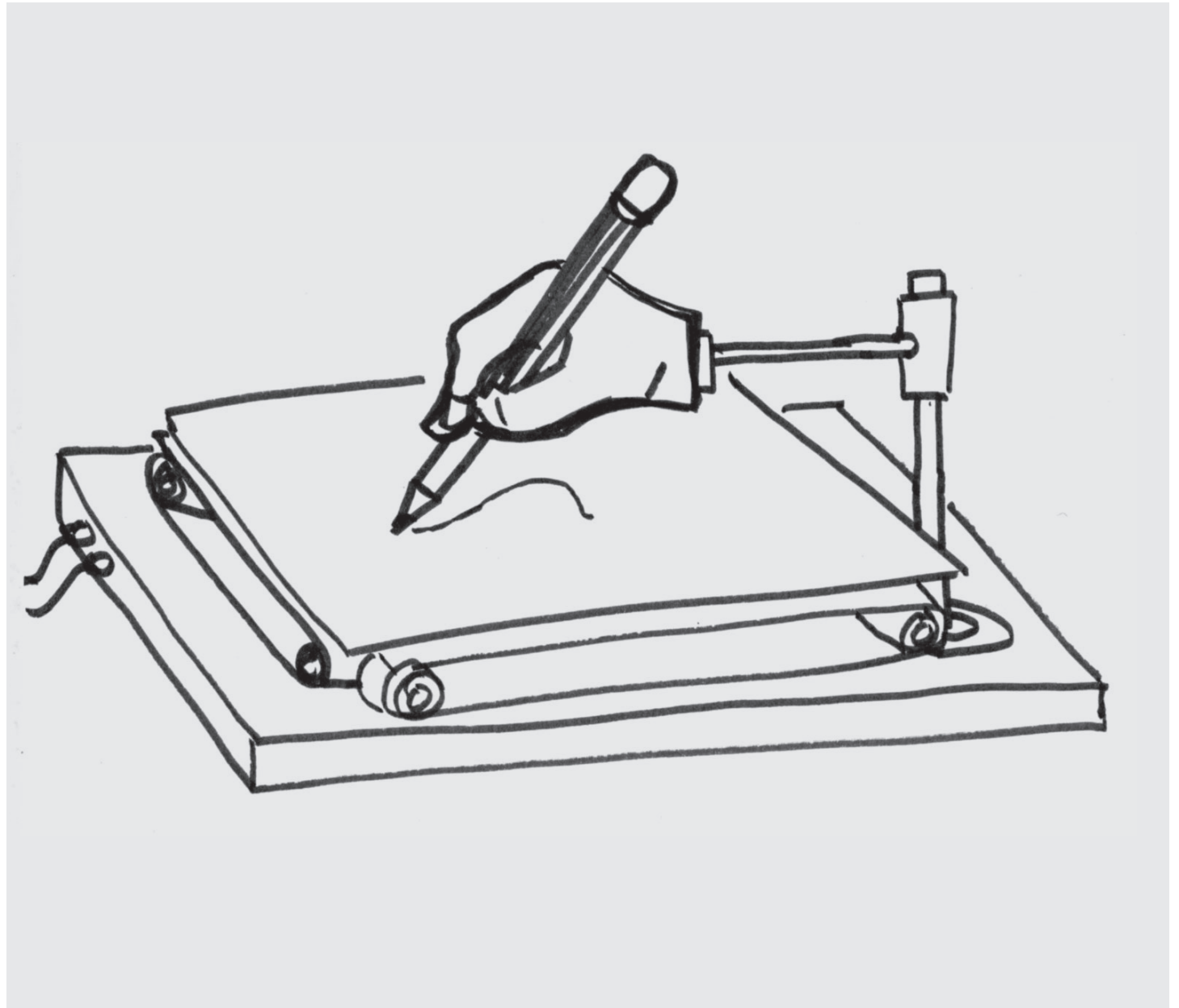

PROJECT PROPOSAL:

THE NEW CARTE DE VISITE

Num, vellabo. Rat officto erovitio consequunt, soluptatem harument faccae quassuntia non nosant utem faceate cum ulparis molor simil ium laceper umquos nissumet, consecis eatis min explia exceat.

Ehendem eum alit, optatib eritatq uaspers pereiumende ipsam quianditior resequi atiasi odipieni offic te consequi busam nos si re nonet molor anderit veribus, quuntus in cus. Ur? Occatus.



PROJECT PROPOSAL:

MEDIATED SOMATIC TRACKING

Experiment in alternative forms of representing the self by tracking the body with sensory technology and producing an artifact from the gathered data.

PH TEST

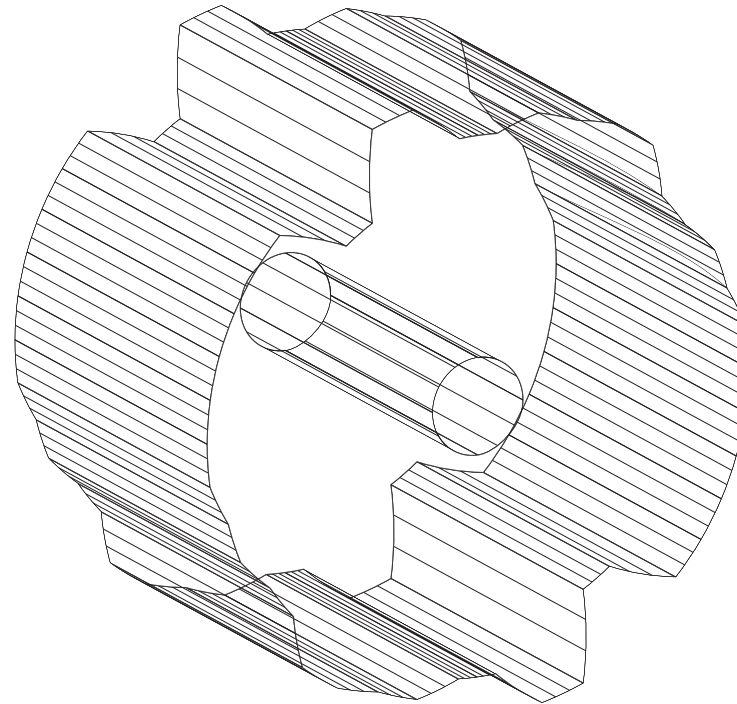

HUNTER

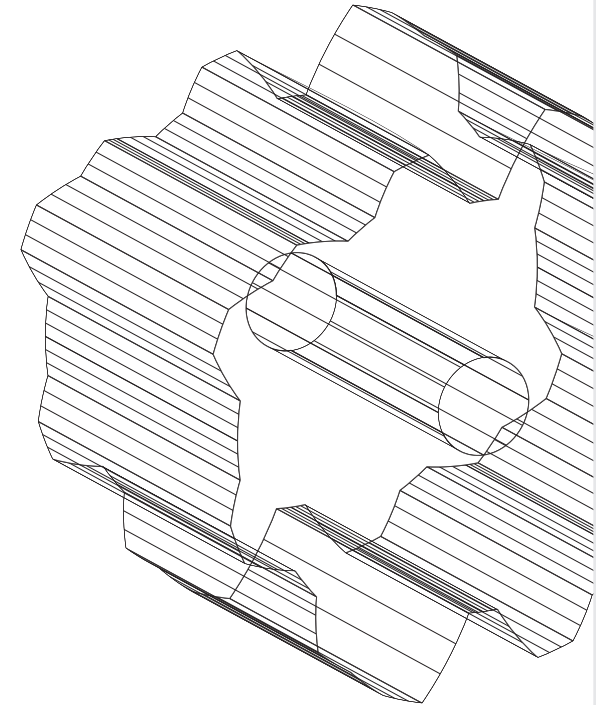

CHRIS

PROJECT PROPOSAL:

TWITTER TEE

Produce a tee shirt that has the capability to display one's Twitter feed. This project touches on three points, mainly: How messages are affected when they are narrowcasted instead of broadcasted, How meaning is associated when content is attached to its producer, How emotional connectivity is a part of when one wears the feed of another person.



PROJECT PROPOSAL:

TWITTER RECEIPT

Make Twitter posts tangible by feeding twitter RSS to a handful of receipt printers mounted on the wall.

The posts move downward toward a trash can as they printout and are eventually thrown out.



PROJECT PROPOSAL:

SOCIAL MEDIA GREETING CARDS

Produce a series of greeting cards taking visuals and content from an individuals social media sites.

These cards seek to question how meaning is attached to messages when produced in tangible forms and in different contexts.

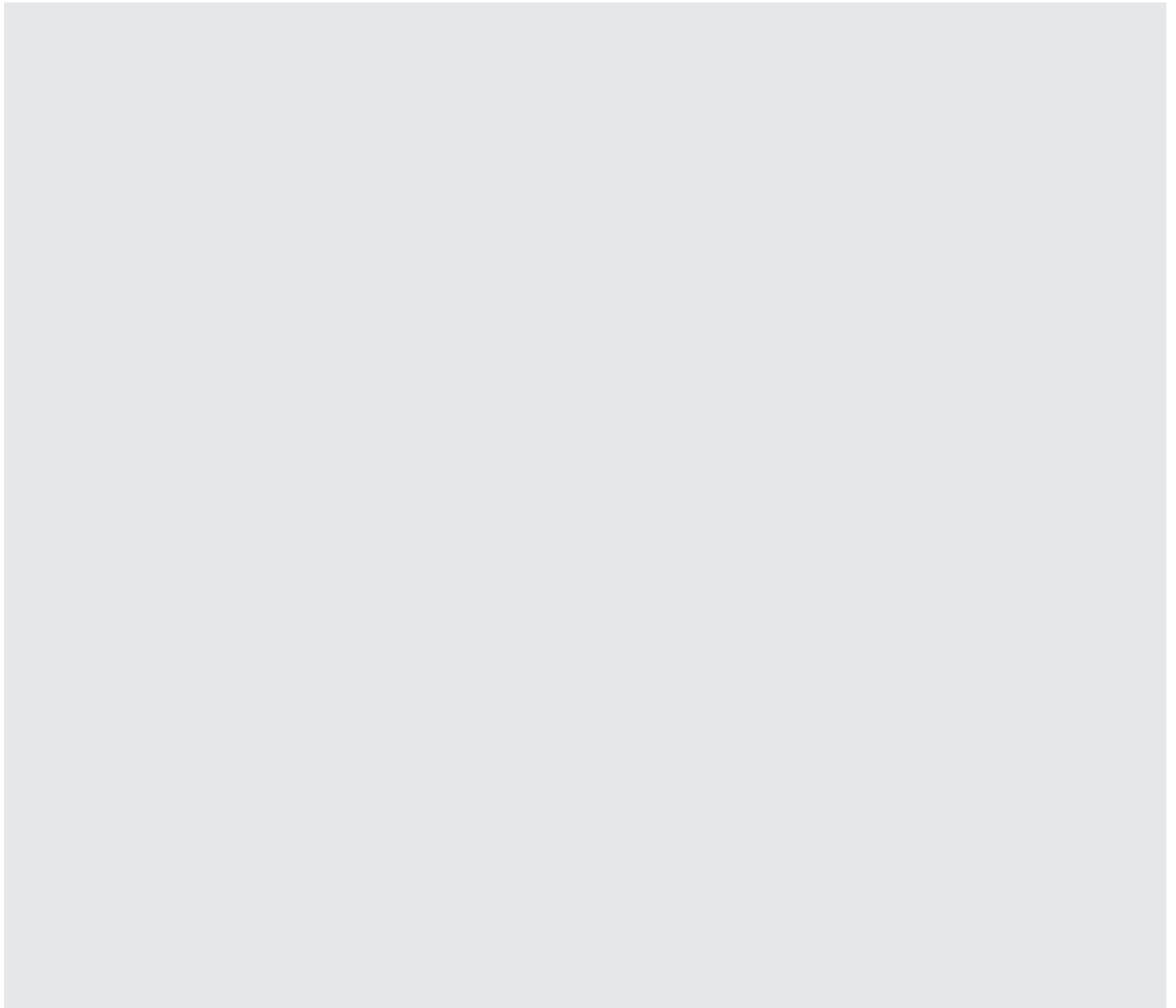

PROJECT PROPOSAL:

FASTER THAN AN EMAIL

Experiment with the affordances of the digital and physical by trying to win a race between me and my emails.

For a period of time, each time I send an email I will try to arrive to the recipient either physically or with a tangible note before the recipient takes the time to read the email I sent.

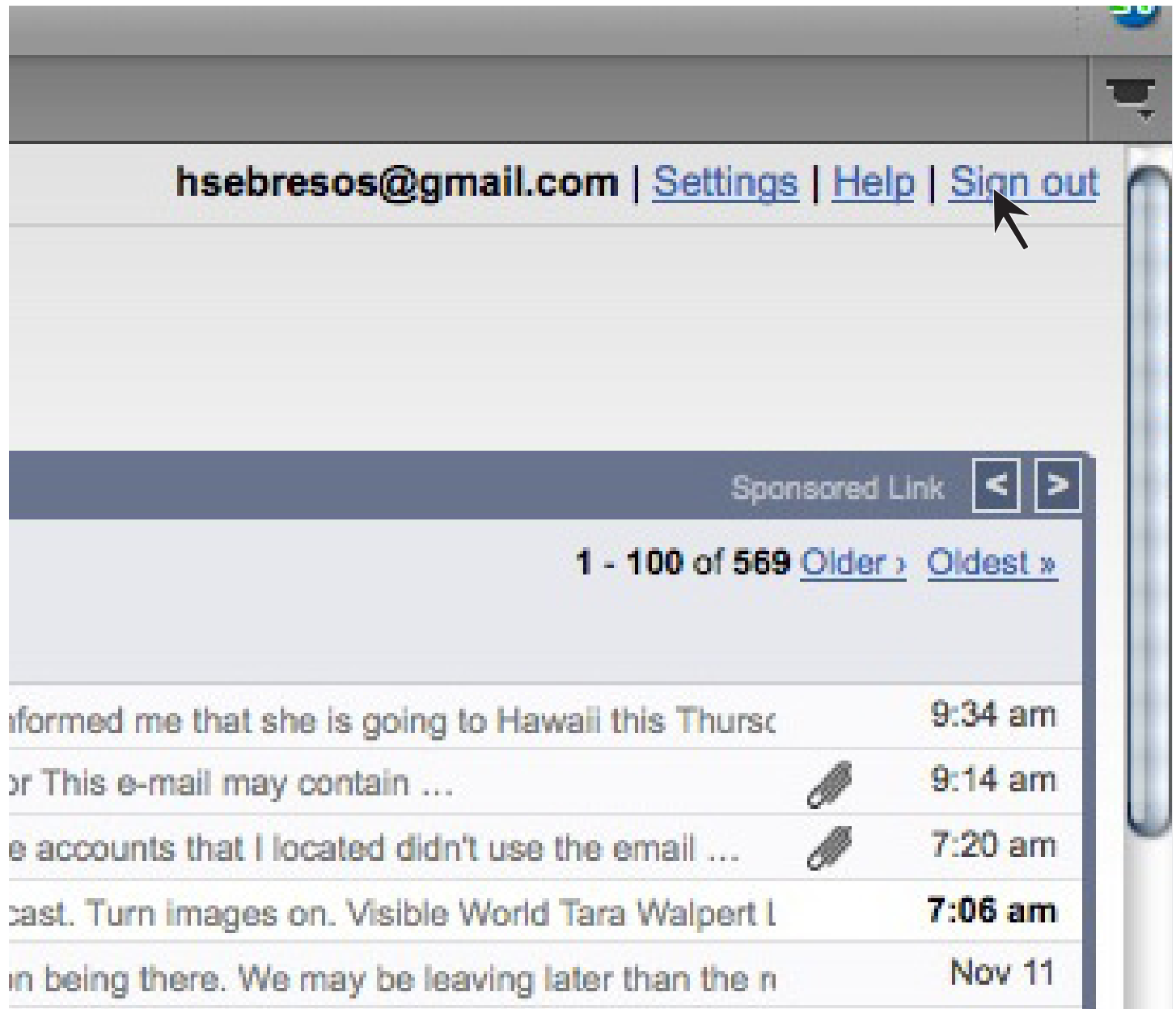

PROJECT PROPOSAL:

WORLD WIDE WRETCHEDNESS

Produce a short video that highlights the negative tone of communication on the internet. Take note of the statistical figures such as, "It takes 4.5 comments on an average YouTube video before an explicit or derogatory word is mentioned." Use this video as a commentary of the virtual self and its lack of connection to the physical self.

actually she has a video of her without make up and she
it

beelze18 (6 hours ago)

I cant bealive i watched the whole thing, ima go kill my
humor, or rip it at least like carlos mencia.

thedetecive22 (6 hours ago)

u suck

poonter31 (10 hours ago)

STFU faggot. Justine is a babe, look at her, you can te
without makeup.

Johnnyboyinthehouse (10 hours ago)

pig FTW

PROJECT PROPOSAL:

TIME PLANT

A mechanical plant grows based on how often people spend time off-line.

Using the mechanical turk an assignment will be given that asks people to take five minutes to engage someone else off-line.

Each vote supports the growth of a mechanical plant.

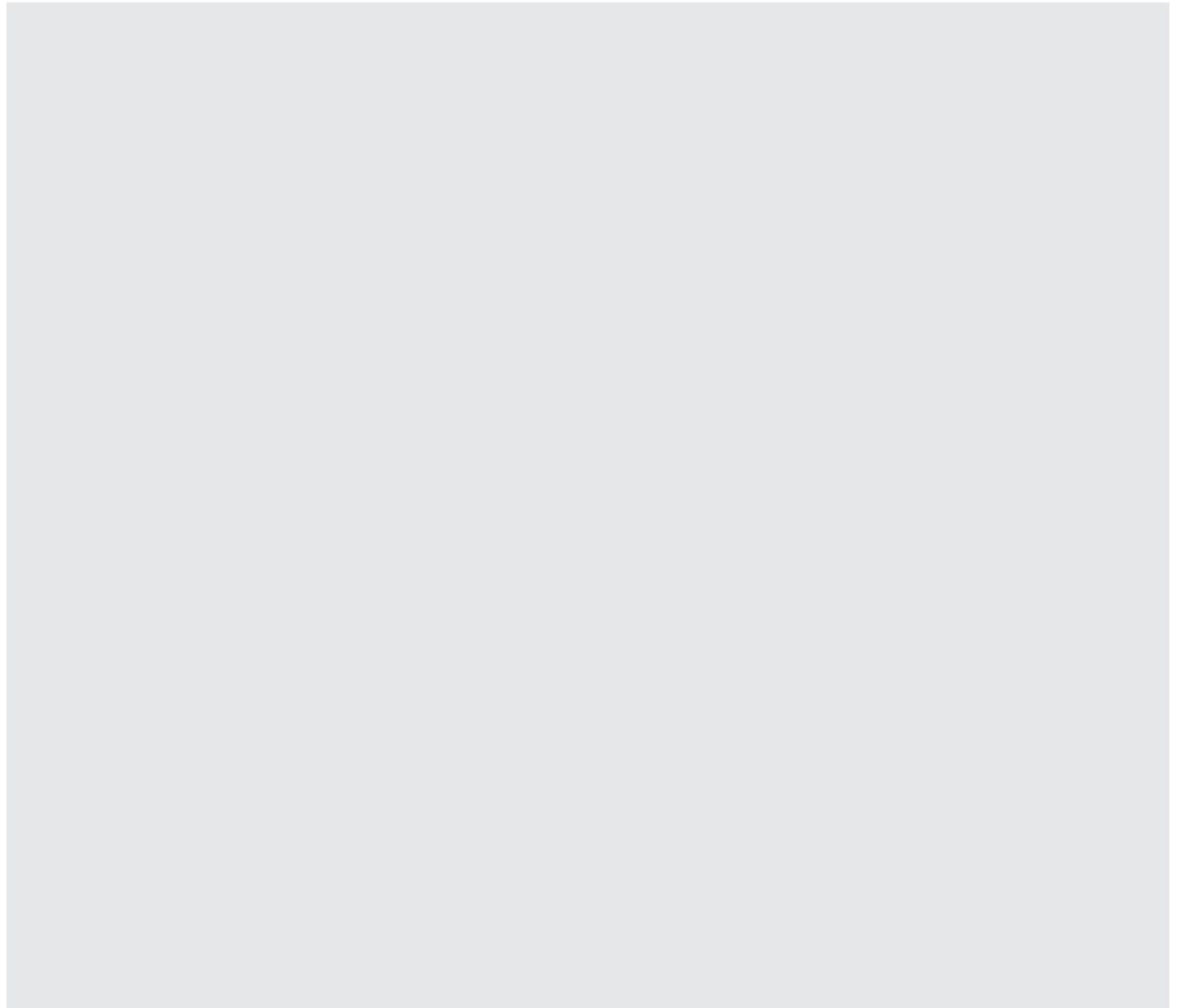

PROJECT PROPOSAL:

MARKER POLL

Experiment with social connectivity and network data visualization with tangible media.

Create a poll of two topics such as Tangible vs. Digital. Allow online visitors to vote on the poll but graph the results with a tangible medium in real-time.

Servo motors attached to markers move depending on the amount of votes they receive.

